



Addendum Number 1

August 8, 2025

From: Procurement Department

Re: Invitation to Bid High Mast Lighting Fixtures

Issue Date: 8/2/25

Due Date: 8/20/25

1. This addendum is for a change on the item to add option for secondary 10kV/5kA SPD. This will make the item description ERHM 03 0 90 VW 7 40 N 1 4B Gray R. See attached updated specification and invitation to bid form. Please utilize these specifications and invitation to bid form for submission.

End of Addendum Number 1

INVITATION FOR BID

**THIS FORM MUST BE COMPLETED AND
SIGNED FOR YOUR BID TO BE CONSIDERED VALID.**

Address to: Procurement Manager
City of Kingsport
415 Broad Street
Kingsport, TN 37660
Phone (423) 229-9419 or Fax (423) 224-2433

Date Issued: 8/2/25
F.O.B. Kingsport

Total Number of Pages: 8

This sealed bid in the original copy, subject to the terms and conditions on the attachment, will be received by the Procurement Manager until 4:00 P.M., Eastern Time on August 20, 2025, at which time will be publicly opened in the Conference Room # 436, City Hall, 415 Broad Street, Kingsport, Tennessee. **IN THE LOWER LEFT CORNER OF YOUR ENVELOPE ADDRESSED TO ABOVE, MARK YOUR ENVELOPE "HIGH MAST LIGHTING FIXTURES" AND DATE OF THE BID OPENING.**

READ TERMS AND CONDITIONS BEFORE COMPLETING THIS FORM

Item	Quantity	U/I	Description	Unit Price	Total Price
01	55	EA	<p>Evolve ERHM 03 0 90 VW 7 40 N1 4B Gray R High Mast LED Roadway Luminaire This product has been pre-approved by TDOT, no substitutes will be accepted Please see attached specifications attached</p> <p>Delivery Terms: 1. Delivery no later than _____ business days after acceptance of order which shall be defined as purchase order date.</p> <p>Liquidated Damages: As actual damages for any delays in delivery of the vehicles/equipment which the bidder is required to perform as per this bid document are difficult to determine, the Bidder shall be liable for and shall pay to the Owner the sum of Fifty Dollars (\$50.00) as fixed, agreed and liquidated damages for each business day of delay per purchase order and not per unit from the number of days stipulated for delivery and for deficiency correction</p>		

In compliance with this Invitation for Bid and subject to all conditions thereof, the undersigned agrees, if this bid is accepted within 60 days from the date of the opening, to furnish all the material/service upon which prices are quoted, delivered at the designated point(s) within the time specified.

- (A) Terms: NET
 (B) Delivery/Job completion within _____ days after notification.
 (C) Specification/Letter of explanation enclosed: YES () NO ()

Handwritten Signature of Authorized Representative

Name of Firm

Date

THIS FORM MUST BE SIGNED TO BE CONSIDERED COMPLETE

TERMS AND CONDITIONS

1. Bids must be submitted on this form only and bear the handwritten signature of an authorized representative of the firm to be considered valid. This is a request for quote and can be faxed to (423)224-2433. No telephone bid(s) will be accepted. Unless otherwise stated by the City, no bidder may withdraw his bid within a period of sixty (60) days after the date set for the reply date.
2. If prices are quoted FOB Kingsport, TN., delivery to City of Kingsport locations shall be without additional charge.
3. Failure to examine any drawings, specifications, and instructions will be a bidder's risk. If bidder is in doubt as to the true meaning of any part of the drawings, specifications and instructions or other documents, he should submit a written request for an interpretation to the Procurement Manager. An interpretation of the documents will be made only by addendum issued by the Procurement Manager to each firm to whom an invitation was forwarded. The City will not be responsible for explanation or interpretations of bid documents except as issued in accordance herewith.
4. Where a brand or trade name appears in the specifications, it is understood that the brand or trade name referred to, or its approved equivalent, shall be furnished. If no mention is made of any exceptions, it is assumed that he is bidding on the article mentioned and not an approved equivalent.
5. The bidder is requested to attach brochure-type information on the supplies furnished. All guaranteed and warranties should be clearly stated.
6. Taxes. The City is exempted from Federal excise taxes and state and local sales taxes and bidders must quote prices which do not include such taxes. An exemption certificate will be furnished upon request.
7. Bids and modifications or corrections thereof received after the closing time specified will not be considered. The City is not responsible for delays in delivery by mail, courier, etc.
8. Any exceptions to these terms and conditions or deviations from written specifications will be shown in writing and attached to the bid form.
9. Any alteration, erasure, addition to or omission of requested information, change of the specifications, or bidding schedule, is made at the risk of the bidder and may result in the rejection of the bid, unless such changes are authorized by the specifications.
10. In the event cash discounts are offered by the bidder, the discount date shall begin with the date of the invoice or the date of receipt of all material covered by the order/contract, whichever is the later date.
11. Charges for boxing or cartage will not be allowed unless previously agreed upon.
12. Default in promised delivery or completion of service and/or failure to comply with specifications authorizes the City to purchase materials, supplies, vehicles, equipment, or services elsewhere and charge the difference to defaulting Vendor.
13. Bidder agrees to defend and save City of Kingsport from and against all demands, claims, suits, costs, expenses, damages and judgments based upon infringement of any patents relating to goods specified in this order or the ordinary use or operation of such goods by City or use or operation of such goods in accordance with bidders direction.
14. In case of error or discrepancy in the mathematics of the bid price, the unit prices shall prevail.
15. By submission of a signed bid, the bidder certifies total compliance with Title VI and Title VII of the Civil Rights Act of 1964, as amended, and all regulations promulgated thereunder.
16. Contracts and purchases will be made or entered into with the lowest, responsible, compliant bidder meeting specifications for the particular grade or class of material, work or service desired in the best interest and advantage to the City of Kingsport. Responsible bidder is defined as a bidder whose reputation, past performance, and business and financial capabilities are such that he would be judged by the appropriate City authority to be capable of satisfying the City's needs for a specific contract or purchase order.
17. The City reserves the right to determine the low bidder either on the basis of the individual items or on the basis of all items included in its INVITATION TO BID, unless otherwise expressly provided in the INVITATION TO BID. The City reserves the right to accept any item or group of items of any kind and to modify or cancel in whole or in part, its INVITATION TO BID.
18. All contracts or purchase orders issued for this award will be governed by the laws of the State of Tennessee without regard to its conflict of laws principals.
19. Any dispute arising out of any aspect of this purchase order or a contract shall be litigated in state court in Kingsport, Sullivan County, Tennessee or the federal court for the Eastern District of Tennessee, Northeastern Division. However, neither party shall be obligated to provide any type of pre-suit notice before initiating a cause of action. The parties waive their right to a jury trial. The parties hereby consent to the mandatory and exclusive venue and jurisdiction of the state court located in Kingsport, Tennessee or the Federal court for the Eastern District of Tennessee. Service of process shall comply with the Tennessee Rules of Civil Procedure or applicable federal rules, and City does not agree to any other service of process procedure.
20. The City, in accordance with its governing directives, reserves the right to reject any and all bids, to waive any informality or irregularities in bids and unless otherwise specified by the bidder, to accept any item.
21. The contract will be awarded for a period of one (1) year with a renewal option on an annual basis in one (1) year increments providing all terms, conditions and cost are acceptable to both parties. The City reserves the right to rebid at the end of any contract period.
22. CONFLICT OF INTEREST:
 - a) No Board Member or officer of the City of Kingsport or other person whose duty it is to vote for, let out, overlook or in any manner superintend any of the work for the City of Kingsport has a direct interest in the award of the vendor providing goods or services.
 - b) No employee, officer or agent of the grantee or sub-grantee will participate in selection, or in the award or administration of an award supported by Federal funds if a conflict of interest, real or apparent, would be involved. Such a conflict would arise when the employee, officer or agent, any member of their immediate family, his or her partner, or an organization, which employs, or is about to employ, any of the above, has a financial or other interest in the firm selected for award.

- c) The grantee's or sub-grantees officers, employees or agents will neither solicit nor accept gratuities, favors or anything of monetary value from vendors, potential vendors, or parties to sub-agreements.
- d) Do you or any officers/part-owners/stake-holders/employees of this company have any relative(s) (relatives include spouse, children, stepchildren or any to whom you are related by blood or marriage) that are currently employed by the City of Kingsport, Tennessee, including the Kingsport City School System or serve on the Kingsport Board of Mayor and Aldermen or the Kingsport Board of Education? ____Yes ____No
If you answered yes please state the name and relationship of the employee or member of the Kingsport Board of Mayor and Aldermen or Kingsport Board of Education member _____
- e) Are you or any officers/part-owners/stake-holders/employees of this company also employees of the City of Kingsport, including the Kingsport City School System or serve on the Kingsport Board of Mayor and Aldermen or Kingsport Board of Education?
____Yes ____No
If you answered yes please state the name of the employee or board member

- f) By submission of this bid, the vendor is certifying that no conflicts of interest exist.
23. DRUG FREE WORKPLACE REQUIREMENTS:
- a) Private employers with five or more employees desiring to contract for construction services attest that they have a drug free workplace program in effect in accordance with TCA 50-9-112.
24. ELIGIBILITY:
- a) The vendor is eligible for employment on public contracts because no convictions or guilty pleas or pleas of nolo contendere to violations of the Sherman Anti-Trust Act, mail fraud or state criminal violations with an award from the State of Tennessee or any political subdivision thereof have occurred.
25. GENERAL:
- a) Vendor fully understands the preparation and contents of the attached offer and of all pertinent circumstances respecting such offer.
- b) Such offer is genuine and is not a collusive or sham offer.
26. IRAN DIVESTMENT ACT:
- a) Concerning the Iran Divestment Act (TCA 12-12-101 et seq.), by submission of this bid/quote/proposal, each vendor and each person signing on behalf of any vendor certifies, and in the case of a joint bid/quote/proposal, each party thereto certifies as to its own organization, under penalty of perjury, that to the best of its knowledge and belief that each vendor is not on the list created pursuant to § 12-12-106.
27. NON-COLLUSION:
- a) Neither the said vendor nor any of its officers, partners, owners, agents, representatives, employees or parties interest, including this affiant, has in any way colluded, conspired, connived or agreed, directly or indirectly, with any other responder, firm, or person to submit a collusive or sham offer in connection with the award or agreement for which the attached offer has been submitted or to refrain from making an offer in connection with such award or agreement, or collusion or communication or conference with any other firm, or, to fix any overhead, profit, or cost element of the offer price or the offer price of any other firm, or to secure through any collusion, conspiracy, connivance, or unlawful agreement any advantage against the City of Kingsport or any person interested in the proposed award or agreement.
- b) The price or prices quoted in the attached offer are fair, proper and not tainted by any collusion, conspiracy, connivance, or unlawful agreement on the part of the firm or any of its agents, representatives, owners, employees, or parties in interest, including this affiant.
28. BACKGROUND CHECK REQUIREMENT FOR SCHOOL SYSTEM SUPPLIERS:
- a) In submitting this bid/quote/proposal, you are certifying that you are aware of the requirements imposed by TCA § 49-5-413 (d) to conduct criminal background checks through the Tennessee Bureau of Investigation and the Federal Bureau of Investigation on yourself and any of your employees who may come in direct contact with students or who may come on or about school property anytime students are present. You are further certifying that at no time will you ever permit any individual who has committed a sexual offense or who is a registered sex offender to come in direct contact with children or to come on or about school property while students are present.
29. NON-BOYCOTT OF ISRAEL AFFIDAVIT
- a) Concerning the Non-Boycott of Israel Act (TCA 12-4-1 et seq.), by submission of this bid/quote/proposal, each supplier and each person signing on behalf of any supplier certifies, and in the case of a joint bid/quote/proposal, each party thereto certifies as to its own organization, under penalty of perjury, that to the best of its knowledge and belief that each supplier is not boycotting Israel pursuant to § 12-4-1 and will not during the term of any award. Note: Applicable only to contracts of \$250,000 or more and to suppliers with 10 or more employees.

ERHM Gen 03

High Mast LED
Roadway Luminaire

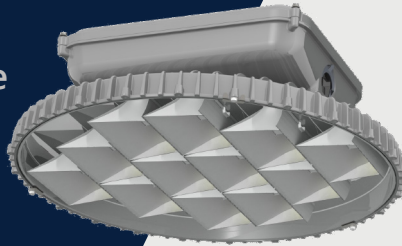

Project Name _____

Date _____ Type _____

Notes _____

The Evolve® LED High Mast is an LED solution for expressway, freeway interchanges and other large area applications. Current's unique reflective optics are designed to optimize application efficiency and minimize glare. The ERHM luminaire is an efficient solution lowering energy consumption as compared to traditional HID fixtures providing operating cost savings.

CONSTRUCTION

Housing:	Cast aluminum optical and electrical housings.
Lens:	Impact resistant tempered glass
Paint:	Corrosion resistant powder paint, ≥ 2.0 mil thickness Standard = Gray (RAL & custom colors available) Optional = Coastal Finish
Weight:	~50 lbs. (~23 kgs.)

OPTICAL SYSTEM

Lumens:	28,800-110,000
Distribution:	Type II Narrow/Wide Type III Type III/IV Type V High Angle
Efficacy:	129 - 177 LPW
CCT:	3000K, 4000K & 5000K
CRI:	≥ 70

ELECTRICAL

Input Voltage:	120-277V or 277-480V
Input Frequency:	50/60Hz
Power Factor:	≥ 0.9% at rated watts
Total Harmonic Distortion:	≤ 20% at rated watts
EMI:	FCC 47 CFR Part 15 Class A

SURGE PROTECTION*

Standard	Optional
10kV/5kA	Secondary 10kV/5kA (R Option) or Secondary 20kV/10kA (T Option)

*Per ANSI C136.2-2018

WARRANTY

5 Year (Standard)

10 Year (Optional)

LUMEN MAINTENANCE

Projected Lxx per IES TM-21-11 at 25°C

SKU	Lumens	Distribution	LXX @ Hours		
			25,000 HR	50,000 HR	60,000 HR
ERHM	30-70	VW	99	99	98
	80,90	VW	98	95	94
	100	VW	96	92	90
	30-40	A6, B6, C6, D6	99	99	98
	50	A6, B6, C6, D6	94	87	84
	60	A6, B6, C6, D6	97	95	94
	70	A6, B6, C6, D6	93	86	83
	80	A6, B6, C6, D6	96	93	91
	90	A6, B6, C6, D6	90	80	76
	100	A6, B6, C6, D6	84	70	65

NOTES: Projected Lxx based on LM-80 (≥12,000 hour testing). Accepted Industry tolerances apply to initial luminous flux and lumen maintenance measurements.

AMBIENT TEMPERATURE FACTOR

Ambient Temp (°C)	Initial Flux Factor	Ambient Temp (°C)	Initial Flux Factor
10	1.02	30	0.99
20	1.01	40	0.98
25	1		

RATINGS

Operating Temperature:	-40°C to 40°C*
Vibration:	3G per ANSI C136.31
LM-79:	Tested in accordance with IES Standards
RoHS:	Complies with the material restrictions of RoHS

*Contact Manufacturer for units ≥ 100K lm

CONTROLS

Dimming:	Standard - 0-10V Optional - DALI (Option U)
Sensors:	Photo Electric Sensors (PE) available LightGrid+™ Compatible



ERHM 03

7

4 B

PROD. ID	GEN	VOLTAGE	LUMENS	DISTRIBUTION	CRI	CCT	DIMMING	CONTROLS PER ANSI C136.41	MOUNTING	COLOR	OPTIONS
E = Evolve	03	0 = 120-277 ¹	30	A6 = Type II Narrow	7 = 70 ⁵	30 = 3000K ²	N = No Dimming Control Wiring	1 = None	4B = 4 Bolt (std)	GRAY = Gray	F = Fusing
R = Roadway		1 = 120	40	B6 = Type II Wide		40 = 4000K	D = Dimming Control Wiring Included ⁴	A = 7-Pin Receptacle		BLCK = Black	G = Internal Bubble Level
H = High		2 = 208	50	C6 = Type III		50 = 5000K		D = 7-Pin Receptacle with Shorting Cap			R = Secondary 10kV/5kA SPD
M = Mast		3 = 240	60	D6 ⁶ = Type III/IV				E = 7-Pin Receptacle with Long Life non-Dimming PE Control			T = Secondary 20kV/10kA SPD ⁸
		4 = 277	70	VW = Type V High Angle							U = DALI ^{6,8,9}
		5 = 480 ⁸	80								V1 = Field Adjustable drive current feature (FAM) ¹
		D = 347 ⁸	90								Y = Coastal Finish ³
		E = 277-480V ^{1,8}	10								XXX = Special Options
			11 ^{6,7}								

¹ Not available with fusing. Fusing requires discrete voltage selection to ensure proper fusing wiring.

² Select 3000K CCT for IDA approved units.

³ Recommended for installations within 750 feet from coast. Lead time varies, check with factory.

⁴ Dimming control wiring included to connect dimming control external to the fixture.

⁵ 70 CRI Typical.

⁶ Contact manufacturing for availability.

⁷ Available only in VW distribution.

⁸ May not be available in some configurations.

⁹ U Option may add ~1% on power Consumption.

SUGGESTED HID REPLACEMENT

- 28,800 - 40,000 lm to replace 400W HID & MH High Mast luminaires.
- 47,000 - 60,000 lm to replace 750W HID & MH High Mast luminaires.
- >60,000 lm to replace 1000W HID & MH High Mast luminaires.

Note: actual replacement lumens may vary based upon mounting height, pole spacing, design criteria, etc.

Previous	Optical Pattern	Latest	New Optical Pattern
E1	Type II Med	B6	Type II Wide
G1	Type III Extra Wide	C6	Type III
F1	Type IV Wide	D6	Type III/IV
VS	Type V Short	VW	Type V High Angle
VM	Type V Med	VW	Type V High Angle

The information above is designed to provide a guideline to select the correct luminaire for a roadway application. The best and most accurate way to ensure the proper design is by doing a lighting layout.



LUMEN OUTPUT	DIST.	INITIAL LUMENS		TYPICAL SYSTEM		PRELIMINARY BUG RATINGS	
		5000K/4000K	3000K	LPW (4000K)	WATTS	4000K	3000K
30	A6	30,000	28800	154	195	B3-U0-G3	B3-U0-G3
	B6	30,000	28800	154	195	B3-U0-G4	B3-U0-G4
	C6	30,000	28800	154	195	B3-U0-G5	B3-U0-G4
	D6	30,000	28800	154	195	B2-U0-G4	B2-U0-G4
	VW	31,500	30200	177	178	B5-U0-G4	B5-U0-G4
40	A6	41,900	40200	144	291	B4-U0-G4	B4-U0-G4
	B6	41,900	40200	144	291	B4-U0-G5	B4-U0-G5
	C6	41,900	40200	144	291	B4-U0-G5	B3-U0-G5
	D6	41,900	40200	144	291	B3-U0-G4	B3-U0-G4
	VW	42,000	40300	172	244	B5-U0-G5	B5-U0-G5
50	A6	53,000	49900	136	382	B4-U0-G5	B4-U0-G5
	B6	53,000	49900	136	381	B4-U0-G5	B4-U0-G5
	C6	53,000	49900	136	381	B4-U0-G5	B4-U0-G5
	D6	53,000	49900	136	381	B3-U0-G5	B3-U0-G5
	VW	52,400	50300	170	308	B5-U0-G5	B5-U0-G5
60	A6	62,500	60000	140	447	B4-U0-G5	B4-U0-G5
	B6	62,500	60000	140	447	B4-U0-G5	B4-U0-G5
	C6	62,500	60000	140	447	B4-U0-G5	B4-U0-G5
	D6	62,500	60000	140	447	B3-U0-G5	B3-U0-G5
	VW	61,800	59300	168	368	B5-U0-G5	B5-U0-G5
70	A6	71,800	68900	136	529	B5-U0-G5	B5-U0-G5
	B6	71,800	68900	136	529	B4-U0-G5	B4-U0-G5
	C6	71,800	68900	136	529	B4-U0-G5	B4-U0-G5
	D6	71,800	68900	136	529	B5-U0-G5	B5-U0-G5
	VW	72,000	69100	161	447	B5-U0-G5	B5-U0-G5
80	A6	83,400	80000	137	611	B5-U0-G5	B5-U0-G5
	B6	83,400	80000	137	611	B5-U0-G5	B5-U0-G5
	C6	83,400	80000	137	611	B5-U0-G5	B4-U0-G5
	D6	83,400	80000	137	611	B5-U0-G5	B5-U0-G5
	VW	83,400	80000	159	525	B5-U0-G5	B5-U0-G5
90	A6	92,000	88300	133	692	B5-U0-G5	B5-U0-G5
	B6	92,000	88300	133	692	B5-U0-G5	B5-U0-G5
	C6	92,000	88300	133	692	B5-U0-G5	B5-U0-G5
	D6	92,000	88300	133	692	B5-U0-G5	B5-U0-G5
	VW	94,000	90200	156	603	B5-U0-G5	B5-U0-G5
10	A6	102,000	96900	129	782	B5-U0-G5	B5-U0-G5
	B6	102,000	96900	129	782	B5-U0-G5	B5-U0-G5
	C6	102,000	96900	129	782	B5-U0-G5	B5-U0-G5
	D6	102,000	96900	129	782	B5-U0-G5	B5-U0-G5
	VW	104,000	99800	154	675	B5-U0-G5	B5-U0-G5
11	VW	110,000	105600	152	724	B5-U0-G5	B5-U0-G5

For additional information on ERHM IES files, please refer to LED.com

ERHM03
Type II Narrow
 70,000 Lumens
 4000K
 ERHM3_70A6740__IES

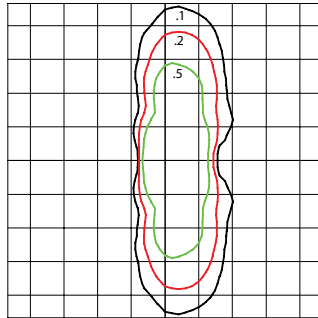

Grid Distance in Units of Mounting Height at 60' Initial Footcandle Values at Grade

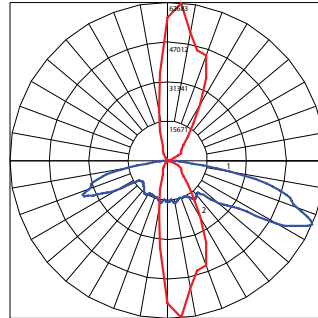

— Vertical plane through horizontal angle of maximum candlepower at 85°
 — Horizontal cone through vertical angle of 66°

ERHM03
Type II Wide
 70,000 Lumens
 4000K
 ERHM3_70B6740__IES

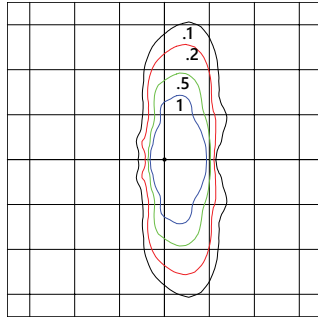

Grid Distance in Units of Mounting Height at 60' Initial Footcandle Values at Grade

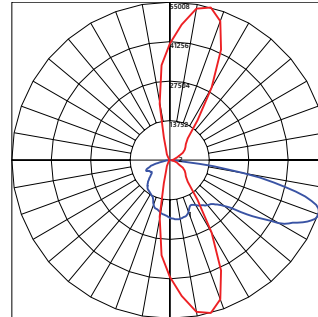

— Vertical plane through horizontal angle of maximum candlepower at 75°
 — Horizontal cone through vertical angle of 70°

ERHM03
Type III Wide
 70,000 Lumens
 4000K
 ERHM3_70C6740__IES

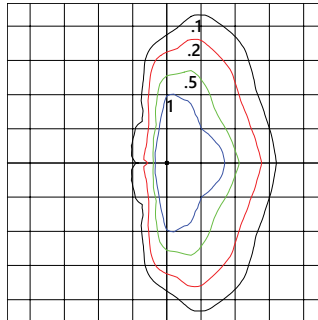

Grid Distance in Units of Mounting Height at 60' Initial Footcandle Values at Grade

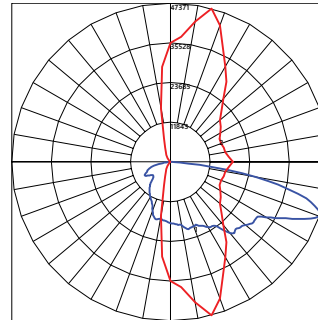

— Vertical plane through horizontal angle of maximum candlepower at 75°
 — Horizontal cone through vertical angle of 70°

³ This optic is designed to address a Roadway Photometric Application and may classify as Type II or III.

ERHM03
Type III/IV
 60,000 Lumens
 4000K
 ERHM3_60D6740__IES

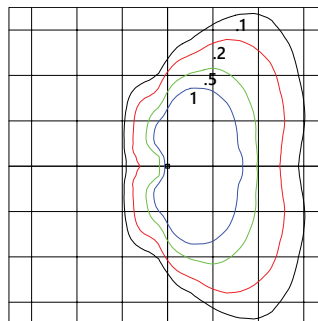

Grid Distance in Units of Mounting Height at 60' Initial Footcandle Values at Grade

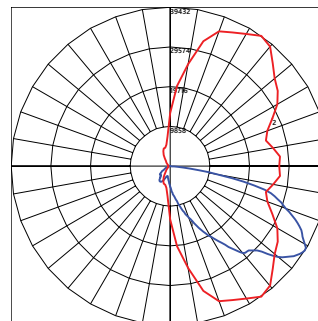

— Vertical plane through horizontal angle of maximum candlepower at 55°
 — Horizontal cone through vertical angle of 58°

ERHM03
Type V
 80,000 Lumens
 4000K
 ERHM3_80VW740__IES

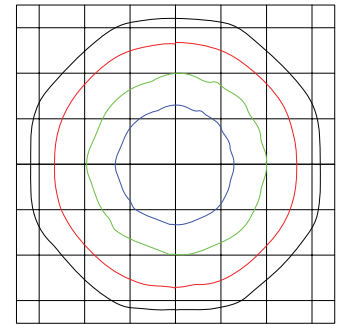

Grid Distance in Units of Mounting Height at 60' Initial Footcandle Values at Grade

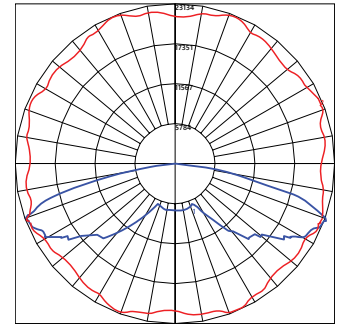

— Vertical plane through horizontal angle of maximum candlepower at 65°
 — Horizontal cone through vertical angle of 67°

ERHM03

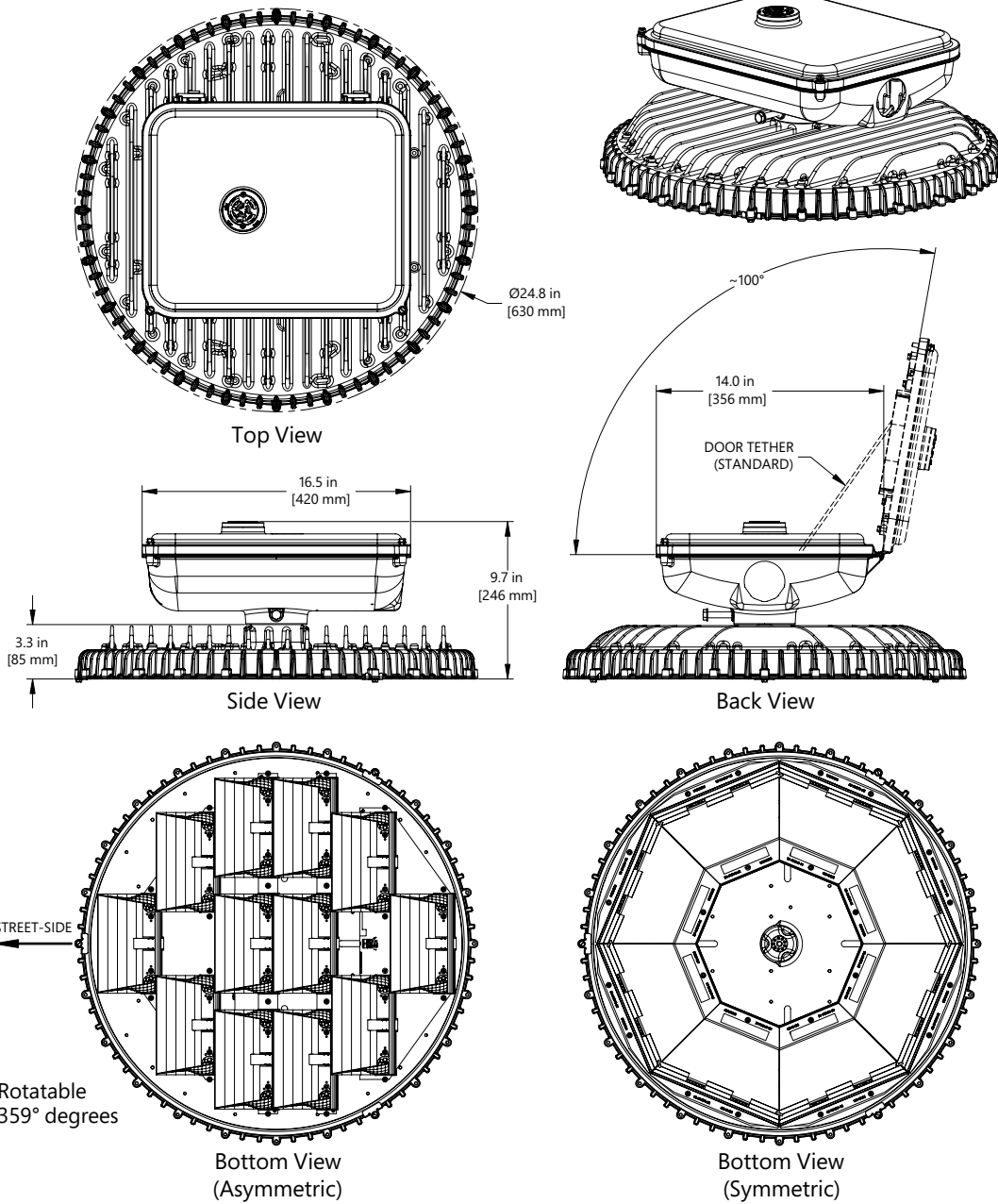

MOUNTING

- 4 Bolt Slipfitter with +/-5 degree of adjustment
- Integral mounting pipe stop
- 2 in. (2.375" OD, 60 mm OD) mounting pipe

EFFECTIVE PROJECTED AREA

- Effective Projected Area: 1.3 ft.² (0.12m²) (Max, no shield)

WEIGHT

- Weight: ~50Lbs (~23kg)

NETWORKED LIGHTING CONTROL



Current's LightGrid+™ Outdoor Lighting Control System is designed for Street and Roadway Applications. It enables remote monitoring, control, and asset management of a single fixture or a group of fixtures through a web enabled Central Management System.